

6 Displacements	Series	(3.6 – 12.9 in <sup>3</sup> /rev)
6 Schluckvolumen		<b>59...211 cm<sup>3</sup>/rev</b>
6 Cylindrée	Parallel	(7.2 – 25.8 in <sup>3</sup> /rev)
6 Desplazamientos		<b>118...423 cm<sup>3</sup>/rev</b>
		<b>Cont                      Int</b>
Maximum Pressure	Series	(2500 psid) (3000 psid)
Eingangsdruck		<b>...170 bar                      ...210 bar</b>
Pression entrée	Parallel	(2500 psid) (3000 psid)
Pressione Maxima		<b>...170 bar                      ...210 bar</b>
Maximum Oil Flow	Series	(20 gpm)
Schluckstrom		<b>...76 lpm</b>
Débit d'huile	Parallel	(30 gpm)
Caudal Maximo de Aceite		<b>...114 lpm</b>
Maximum Speed	Series	<b>890 rpm</b>
Drehzahl	Parallel	<b>782 rpm</b>
Vitesse de rotation		
Velocidad Maxima		
		<b>Cont                      Int</b>
Maximum Torque	Series	(3816 lb in) (4694 lb in)
Max Drehmoment		<b>...431 Nm                      ...530 Nm</b>
Couple	Parallel	(6648 lb in) (7463 lb in)
Torque Maximo		<b>...751 Nm                      ...843 Nm</b>
Maximum Side Load at Key	Series	(700 lb)
Seitenlast		<b>... 3114 N</b>
Charges latérales		
Carga Maxima Lateral		

### High Efficiency, High Flow Two-Speed Motor

Parker's patented two-speed motor utilizes two separate IGR™ power elements on a common shaft. An integral selector valve shifts between high torque, low speed (parallel) operation and high speed, low torque (series) mode in a ratio of 2:1. The use of two power elements eliminates the deficiencies of traditional, single power element designs. In the high torque mode, the motor delivers twice the torque and half the speed that it does in the high speed mode. The selector valve can be open or closed center and may be actuated by an external pilot or optional solenoid valve. The open center selector valve can be shifted "on the fly" while the motor shaft is rotating under load. The selector valve is spring loaded to return to its pilot-pressure-off position. Normal mode of operation is field changeable and can be selected as series or parallel. Pilot pressure must be 300 psi higher than motor case or outlet pressure and may be as high as typical hydraulic system operating pressure.

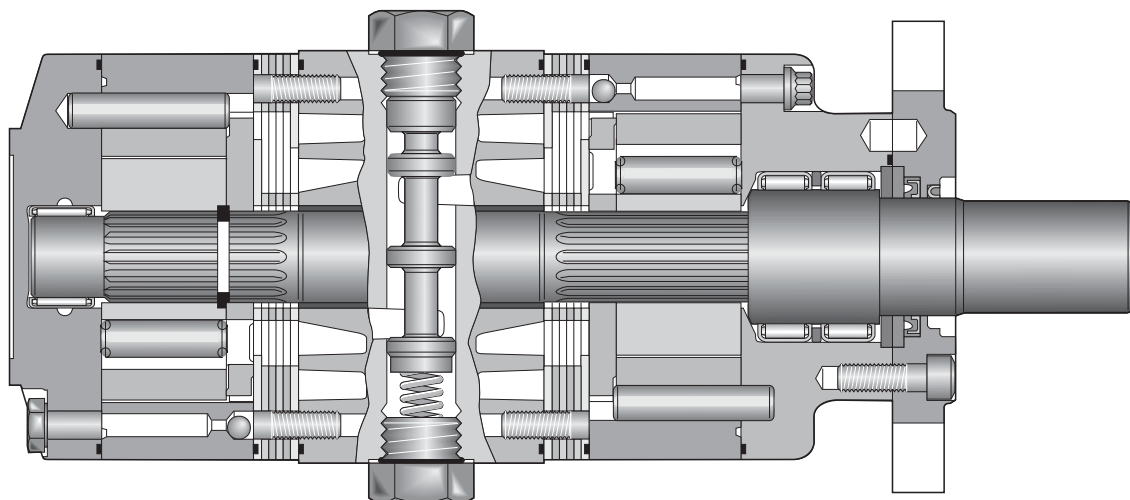

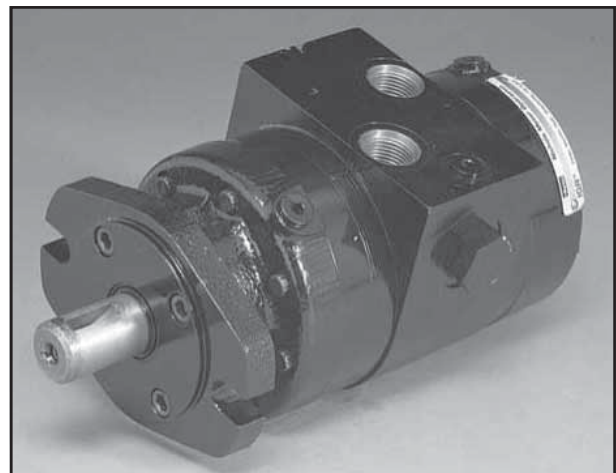
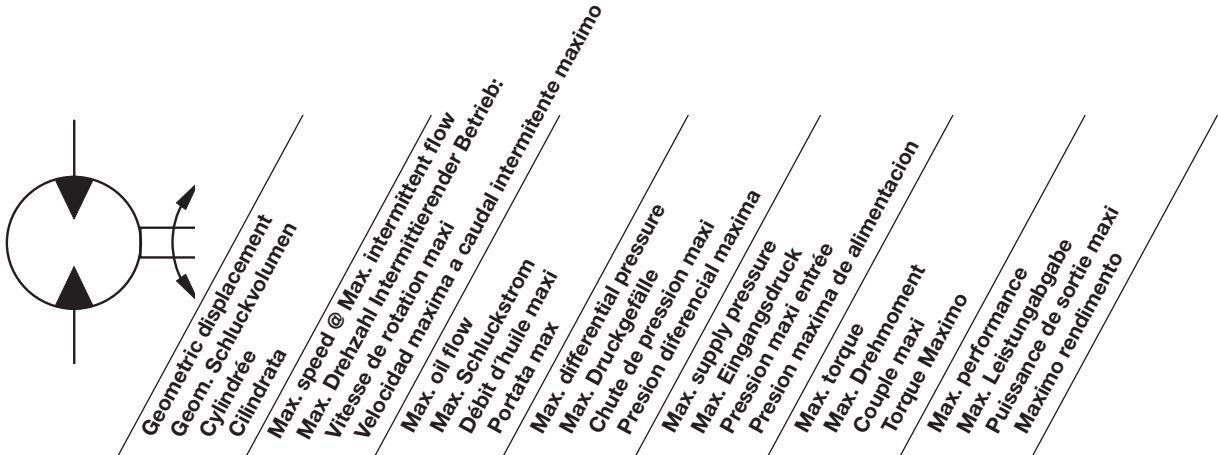

Motor Series 700	cm <sup>3</sup> /rev in <sup>3</sup> /rev	int rev/min	cont / int* l/min g/min	cont / int* bar psid	max bar psig	cont / int* Nm lb-in	max KW HP
072 Series	59 3.6	890	45.4 53.0 12 14	170 210 2500 3000	276 4000	129 154 1146 1366	8.6 11.5
072 Parallel	118 7.2	782	83.3 94.6 22 25	170 210 2500 3000	276 4000	264 309 2338 2739	15.5 20.8
108 Series	88 5.4	843	60.6 68.1 16 18	170 210 2500 3000	276 4000	197 236 1743 2088	12.4 16.6
108 Parallel	177 10.8	656	94.6 113.5 25 30	170 210 2500 3000	276 4000	527 624 4666 5525	26.9 36.1
142 Series	116 7.1	695	75.7 83.3 20 22	170 210 2500 3000	276 4000	260 313 2306 2769	12.8 17.2
142 Parallel	233 14.2	481	113.5 113.5 30 30	170 210 2500 3000	276 4000	518 616 4592 5456	21.8 29.2
176 Series	144 8.8	688	75.7 94.6 20 25	170 210 2500 3000	276 4000	325 392 2818 3472	14.2 19.1
176 Parallel	288 17.6	419	113.5 113.5 30 30	170 210 2500 3000	276 4000	644 709 5707 6283	23.9 32.1
212 Series	174 10.6	580	75.7 113.5 20 30	155 210 2250 3000	276 4000	353 475 3125 4205	13.0 17.4
212 Parallel	347 21.2	352	113.5 113.5 30 30	155 210 2250 3000	276 4000	696 774 6167 6860	21.2 29.4
258 Series	211 12.9	440	75.7 113.5 20 30	155 210 2250 3000	276 4000	431 531 3816 4699	12.3 16.5
258 Parallel	423 25.8	268	113.5 113.5 30 30	137.9 155.1 2000 2250	276 4000	751 843 6648 7463	18.0 24.2

Performance data based on tests using 15W40 oil with a viscosity of 55 cSt (215 SUS) at 54° C (130° F). Performance data is typical. Actual data may vary slightly from one production motor to another.  
Les donnees sur les performances sont basees sur des tests utilisant de l'huile 15W40 d'une viscosite de 55 cSt (215 SUS) a 54°C (130°F). Ces donnees correspondent a des situations typiques. Les donnees reelles peuvent varier legerement d'un moteur de production a l'autre.

Leistungsdaten sind gemessen mit SAE 15W40 bei einer Viskosität von 43,1 Cst bei 54°C. Geringfügige Abweichungen von den Katalogerten sind möglich.

Datos tecnicos obtenidos con aceite 15W40 de 55 cSt (215 SUS) de viscosidad a 54°C (130°F). Los datos proporcionados son valores tipicos. Los valores exactos reales podrian tener una pequena variacion entre distintos motores.

\* Intermittent operation rating applies to 10% of every minute.  
Intermittierende Werte maximal 10% von jeder Betriebsminute.  
Fonctionnement interm. 10% max. de chaque minute d'utilisation.  
Capacidad de funcionamiento intermitente valida para 10% por cada minuto.

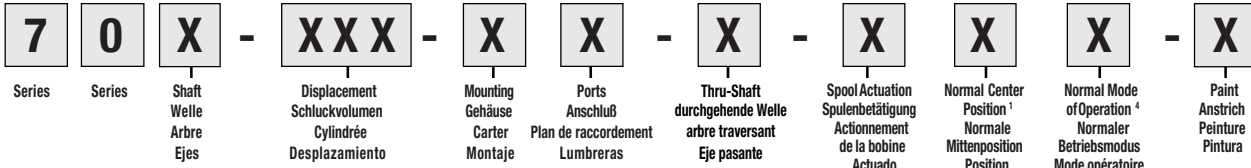

Code	Description
0	1" Keyed
3	1-1/4" Keyed
5	1-1/4"-14 Tooth Spline

Code	cm <sup>3</sup> /U cm <sup>3</sup> /tr cm <sup>3</sup> /giro	in <sup>3</sup> /rev
072	60 / 119	3.6 Series / 7.2 Parallel
108	88 / 176	5.4 Series / 10.8 Parallel
142	116 / 232	7.1 Series / 14.2 Parallel
176	144 / 289	8.8 Series / 17.6 Parallel
212	174 / 348	10.6 Series / 21.2 Parallel
258	211 / 423	12.9 Series / 25.8 Parallel

Code	Description
AM	SAE A 2-Bolt, Manifold
AS	SAE A 2-Bolt, 7/8"-14 SAE
BM	SAE B 2-Bolt, Manifold
BS	SAE B 2-Bolt, 7/8"-14 SAE

Code	Description
0	No Thru Shaft
1	Thru Shaft
E	Encoder Mount

Code	Description
PCL	Remotely Piloted, Closed, Parallel
POL	Remotely Piloted, Open, Parallel
EOL <sup>1</sup>	Solenoid Actuated with Manual Override, Open, Parallel
WOL <sup>1</sup>	Solenoid Actuated without Manual Override, Open, Parallel

<sup>1</sup> Standard Solenoid is 12V DC with 1/4" Spade Connections. Standardausführung ist ein 12-V-Gleichstrom-Solenoid mit 1/4-Zoll-Gabelschuhanschlüssen. Le solénoïde standardisé est du type 12 Vcc avec cosse à fourche de 1/4". La solénoïde estándar es para 12 VCC, con conectores tipo bayoneta de 1/4".

Code	Description
Omit	No Paint
F	Black Paint Schwarz lackiert

Consult factory for other available options, configurations ordering codes and lead times.



072 Series

3.6 cu in / rev

PRESSURE (PSID)

	500	1000	1500	2000	2500	3000	3500
<b>2</b>	242	481	718	941	1143	1313	
	<b>128</b>	<b>127</b>	<b>119</b>	<b>107</b>	<b>88</b>	<b>70</b>	
<b>4</b>	240	476	695	961	1193	1399	1574
	<b>257</b>	<b>256</b>	<b>255</b>	<b>239</b>	<b>219</b>	<b>194</b>	<b>157</b>
<b>6</b>	217	449	697	947	1189	1420	1606
	<b>385</b>	<b>384</b>	<b>382</b>	<b>378</b>	<b>357</b>	<b>329</b>	<b>289</b>
<b>8</b>	187	421	670	910	1155	1384	1610
	<b>513</b>	<b>512</b>	<b>513</b>	<b>511</b>	<b>492</b>	<b>467</b>	<b>418</b>
<b>10</b>	139	372	618	867	1116	1361	1534
	<b>642</b>	<b>640</b>	<b>641</b>	<b>638</b>	<b>628</b>	<b>599</b>	<b>553</b>
<b>12</b>	74	307	553	818	1056	1275	1496
	<b>770</b>	<b>770</b>	<b>768</b>	<b>768</b>	<b>756</b>	<b>708</b>	<b>671</b>
<b>14</b>		240	486	754	994	1191	1448
		<b>898</b>	<b>898</b>	<b>897</b>	<b>882</b>	<b>847</b>	<b>798</b>

FLOW (GPM)

TORQUE (LB IN) 994  
SPEED (RPM) 882

59 cc / rev

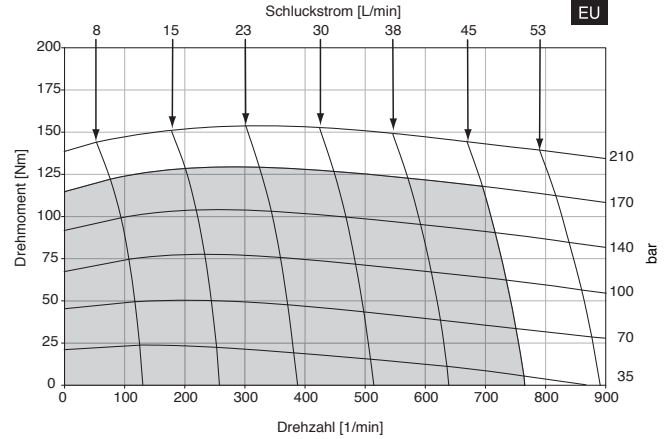

Cont.  Int.

Intermittent operation rating applies to 10% of every minute.  
Fonctionnement interm. 10% max. de chaque minute d'utilisation.

Performance data based on tests using 15W40 oil with a viscosity of 55 cSt (215 SUS) at 54° C (130° F). Performance data is typical. Actual data may vary slightly from one production motor to another.

Les donnees sur les performances sont basees sur des tests utilisant de l'huile 15W40 d'une viscosite de 55 cSt (215 SUS) a 54°C (130°F). Ces donnees correspondent a des situations typiques. Les donnees reelles peuvent varier legerement d'un moteur de production a l'autre.

021 700.indd, js

Intermittierende Werte maximal 10% von jeder Betriebsminute.

Capacidad de funcionamiento intermitente valida para 10% por cada minuto.

Leistungsdaten sind gemessen mit SAE 15W40 bei einer Viskositäet von 43,1 Cst bei 54°C. Geringfügige Abweichungen von den Katalogerten sind möglich.

Datos tecnicos obtenidos con aceite 15W40 de 55 cSt (215 SUS) de viscosidad a 54°C (130°F). Los datos proporcionados son valores tipicos. Los valores exactos reales podrian tener una pequena variacion entre distintos motores.

072 Parallel

7.2 cu in / rev

PRESSURE (PSID)

	500	1000	1500	2000	2500	3000	3500
<b>2</b>	441	889	1272	1650			
	<b>63</b>	<b>59</b>	<b>48</b>	<b>29</b>			
<b>4</b>	481	966	1403	1824	2163		
	<b>128</b>	<b>125</b>	<b>121</b>	<b>104</b>	<b>81</b>		
<b>6</b>	477	957	1401	1813	2186	2485	
	<b>192</b>	<b>187</b>	<b>181</b>	<b>159</b>	<b>121</b>	<b>67</b>	
<b>8</b>	464	964	1428	1850	2249	2578	
	<b>257</b>	<b>251</b>	<b>244</b>	<b>212</b>	<b>161</b>	<b>90</b>	
<b>10</b>	437	941	1427	1836	2243	2620	2968
	<b>321</b>	<b>320</b>	<b>316</b>	<b>283</b>	<b>240</b>	<b>178</b>	<b>115</b>
<b>12</b>	419	913	1401	1833	2229	2589	2960
	<b>385</b>	<b>382</b>	<b>377</b>	<b>353</b>	<b>309</b>	<b>249</b>	<b>174</b>
<b>14</b>	405	881	1384	1824	2220	2582	2952
	<b>449</b>	<b>448</b>	<b>444</b>	<b>420</b>	<b>372</b>	<b>300</b>	<b>235</b>
<b>16</b>	395	858	1363	1801	2192	2571	2940
	<b>513</b>	<b>510</b>	<b>503</b>	<b>485</b>	<b>438</b>	<b>356</b>	<b>280</b>
<b>18</b>	381	821	1327	1769	2183	2520	2931
	<b>577</b>	<b>576</b>	<b>573</b>	<b>553</b>	<b>495</b>	<b>414</b>	<b>334</b>
<b>20</b>	369	799	1308	1772	2146	2513	2904
	<b>642</b>	<b>642</b>	<b>641</b>	<b>616</b>	<b>578</b>	<b>507</b>	<b>405</b>
<b>22</b>	350	779	1272	1742	2114	2503	2884
	<b>706</b>	<b>706</b>	<b>705</b>	<b>678</b>	<b>608</b>	<b>534</b>	<b>452</b>
<b>25</b>		710	1169	1604	1997	2314	2647
		<b>802</b>	<b>801</b>	<b>770</b>	<b>691</b>	<b>606</b>	<b>513</b>
<b>30</b>		653	1066	1444	1776	2097	2366
		<b>962</b>	<b>962</b>	<b>924</b>	<b>830</b>	<b>728</b>	<b>616</b>

FLOW (GPM)

TORQUE (LB IN) 2647  
SPEED (RPM) 513

118 cc / rev

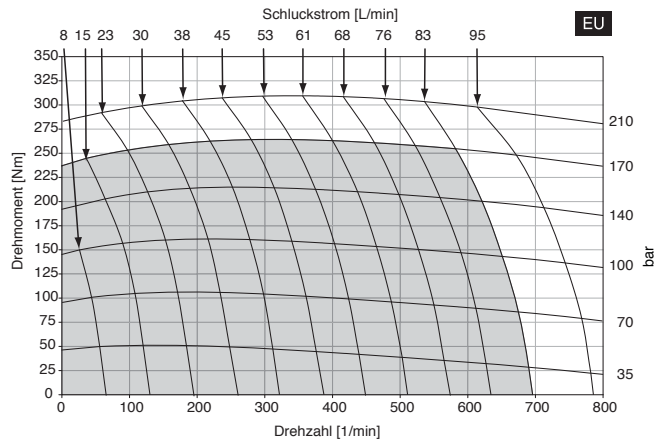

Cont.  Int.

Intermittent operation rating applies to 10% of every minute.  
Fonctionnement interm. 10% max. de chaque minute d'utilisation.

Performance data based on tests using 15W40 oil with a viscosity of 55 cSt (215 SUS) at 54° C (130° F) Performance data is typical. Actual data may vary slightly from one production motor to another.

Les donnees sur les performances sont basees sur des tests utilisant de l'huile 15W40 d'une viscosite de 55 cSt (215 SUS) a 54°C (130°F). Ces donnees correspondent a des situations typiques. Les donnees reelles peuvent varier legerement d'un moteur de production a l'autre.

021 700.indd, js

Intermittierende Werte maximal 10% von jeder Betriebsminute.  
Capacidad de funcionamiento intermitente valida para 10% por cada minuto.

Leistungsdaten sind gemessen mit SAE 15W40 bei einer Viskosität von 43,1 Cst bei 54°C. Geringfügige Abweichungen von den Katalogerten sind möglich.

Datos tecnicos obtenidos con aceite 15W40 de 55 cSt (215 SUS) de viscosidad a 54°C (130°F). Los datos proporcionados son valores tipicos. Los valores exactos reales podrian tener una pequena variacion entre distintos motores.

108 Series

5.4 cu in / rev

88 cc / rev

PRESSURE (PSID)

	500	1000	1500	2000	2500	3000	3500
<b>2</b>	366 86	727 84	1084 80	1431 74	1740 62	2036 52	
<b>4</b>	361 171	725 171	1071 170	1462 163	1816 150	2122 135	2424 110
<b>6</b>	329 257	690 256	1066 255	1443 252	1812 242	2159 224	2455 200
<b>8</b>	289 342	654 341	1029 342	1395 340	1764 330	2118 317	2463 288
<b>10</b>	229 428	593 427	968 427	1337 425	1712 419	2078 406	2375 379
<b>12</b>	151 513	509 513	882 512	1271 511	1636 505	1979 481	2324 459
<b>14</b>	77 599	426 599	800 598	1194 596	1552 588	1874 571	2253 547
<b>16</b>	40 684	342 684	720 683	1133 680	1469 671	1790 649	2146 656
<b>18</b>		259 769	627 769	1031 765	1339 755	1642 738	1961 731
<b>20</b>			536 855	858 850	1139 845	1407 817	1678 788
<b>22</b>			452 940	775 935	1031 930	1277 899	1532 867

FLOW (GPM)

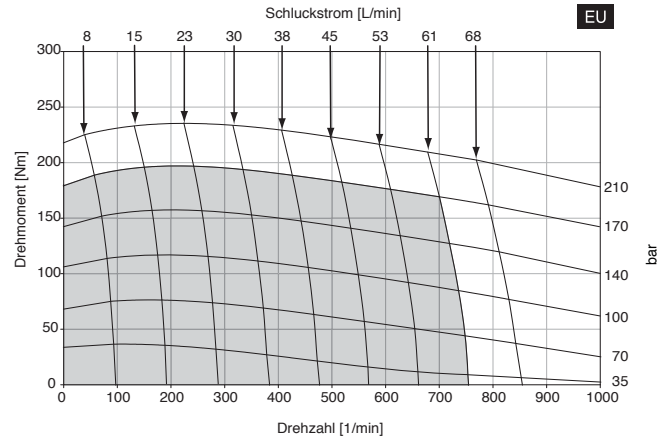

TORQUE (LB IN) 1678  
SPEED (RPM) 788

Cont.  Int.

Intermittent operation rating applies to 10% of every minute.  
Fonctionnement interm. 10% max. de chaque minute d'utilisation.

Performance data based on tests using 15W40 oil with a viscosity of 55 cSt (215 SUS) at 54° C (130° F). Performance data is typical. Actual data may vary slightly from one production motor to another.

Les donnees sur les performances sont basees sur des tests utilisant de l'huile 15W40 d'une viscosite de 55 cSt (215 SUS) a 54°C (130°F). Ces donnees correspondent a des situations typiques. Les donnees reelles peuvent varier legerement d'un moteur de production a l'autre.

021 700.indd, js

Intermittierende Werte maximal 10% von jeder Betriebsminute.

Capacidad de funcionamiento intermitente valida para 10% por cada minuto.

Leistungsdaten sind gemessen mit SAE 15W40 bei einer Viskositäet von 43,1 Cst bei 54°C. Geringfügige Abweichungen von den Katalogerten sind möglich.

Datos tecnicos obtenidos con aceite 15W40 de 55 cSt (215 SUS) de viscosidad a 54°C (130°F). Los datos proporcionados son valores tipicos. Los valores exactos reales podrian tener una pequena variacion entre distintos motores.

108 Parallel  
10.8 cu in / rev

177 cc / rev

PRESSURE (PSID)

	500	1000	1500	2000	2500	3000	3500
<b>2</b>	683 42	1366 40	1970 33				
<b>4</b>	729 85	1455 83	2140 78	2809 65	3383 47		
<b>6</b>	728 128	1465 124	2150 120	2801 105	3399 76		
<b>8</b>	711 171	1469 168	2185 163	2856 142	3491 110		
<b>10</b>	678 214	1442 213	2182 211	2838 189	3482 159	4104 77	
<b>12</b>	651 257	1401 254	2150 252	2833 235	3456 205	4022 109	
<b>14</b>	630 299	1362 298	2104 295	2814 280	3445 246	4012 131	4614 75
<b>16</b>	611 342	1329 340	2095 335	2778 323	3408 290	3981 226	4598 151
<b>18</b>	587 385	1295 383	2051 379	2756 368	3364 333	3898 267	4519 184
<b>20</b>	565 428	1250 426	2013 425	2723 411	3335 382	3878 317	4482 236
<b>22</b>	539 469	1215 469	1962 467	2678 452	3295 409	3847 338	4451 257
<b>25</b>		1123 534	1834 532	2515 513	3108 464	3594 385	4309 290
<b>30</b>		1037 641	1693 639	2313 615	2828 557	3311 462	4151 379

FLOW (GPM)

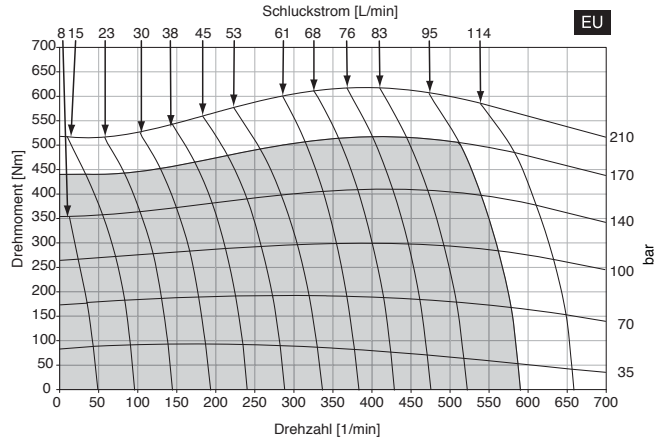

TORQUE (LB IN) 4309  
SPEED (RPM) 290

Cont.  Int.

Intermittent operation rating applies to 10% of every minute.  
Fonctionnement interm. 10% max. de chaque minute d'utilisation.

Performance data based on tests using 15W40 oil with a viscosity of 55 cSt (215 SUS) at 54° C (130° F). Performance data is typical. Actual data may vary slightly from one production motor to another.

Les données sur les performances sont basées sur des tests utilisant de l'huile 15W40 d'une viscosité de 55 cSt (215 SUS) à 54°C (130°F). Ces données correspondent à des situations typiques. Les données réelles peuvent varier légèrement d'un moteur de production à l'autre.

021 700.indd, js

Intermittierende Werte maximal 10% von jeder Betriebsminute.  
Capacidad de funcionamiento intermitente valida para 10% por cada minuto.

Leistungsdaten sind gemessen mit SAE 15W40 bei einer Viskosität von 43,1 Cst bei 54°C. Geringfügige Abweichungen von den Katalogerten sind möglich.

Datos técnicos obtenidos con aceite 15W40 de 55 cSt (215 SUS) de viscosidad a 54°C (130°F). Los datos proporcionados son valores típicos. Los valores exactos reales podrían tener una pequeña variación entre distintos motores.



142 Series

7.1 cu in / rev

PRESSURE (PSID)

	500	1000	1500	2000	2500	3000	3500
<b>2</b>	484 <b>65</b>	964 <b>64</b>	1434 <b>62</b>	1907 <b>58</b>	2319 <b>50</b>	2759 <b>43</b>	
<b>4</b>	474 <b>130</b>	968 <b>130</b>	1444 <b>130</b>	1948 <b>126</b>	2410 <b>118</b>	2819 <b>107</b>	3264 <b>87</b>
<b>6</b>	438 <b>195</b>	930 <b>195</b>	1428 <b>194</b>	1926 <b>192</b>	2417 <b>1987</b>	2875 <b>174</b>	3285 <b>158</b>
<b>8</b>	391 <b>260</b>	889 <b>260</b>	1381 <b>260</b>	1870 <b>259</b>	2359 <b>253</b>	2838 <b>245</b>	3298 <b>226</b>
<b>10</b>	327 <b>325</b>	821 <b>324</b>	1324 <b>324</b>	1804 <b>323</b>	2298 <b>320</b>	2776 <b>313</b>	3215 <b>295</b>
<b>12</b>	249 <b>390</b>	728 <b>390</b>	1226 <b>390</b>	1725 <b>388</b>	2217 <b>385</b>	2664 <b>372</b>	3092 <b>358</b>
<b>14</b>	184 <b>455</b>	643 <b>455</b>	1141 <b>454</b>	1648 <b>452</b>	2116 <b>447</b>	2573 <b>439</b>	3063 <b>427</b>
<b>16</b>	101 <b>520</b>	532 <b>520</b>	1040 <b>519</b>	1558 <b>516</b>	2011 <b>511</b>	2474 <b>501</b>	2949 <b>497</b>
<b>18</b>		439 <b>585</b>	930 <b>584</b>	1441 <b>581</b>	1876 <b>575</b>	2325 <b>564</b>	2790 <b>559</b>
<b>20</b>		300 <b>651</b>	810 <b>650</b>	1275 <b>647</b>	1712 <b>643</b>	2125 <b>629</b>	2535 <b>612</b>
<b>22</b>		249 <b>716</b>	707 <b>715</b>	1169 <b>711</b>	1594 <b>707</b>	1983 <b>692</b>	2386 <b>673</b>

FLOW (GPM)

TORQUE (LB IN) 2535  
SPEED (RPM) 612

116 cc / rev

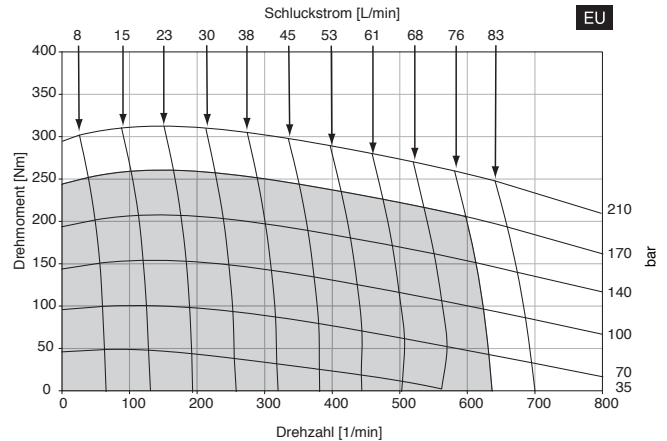

Cont.  Int.

Intermittent operation rating applies to 10% of every minute.  
Fonctionnement interm. 10% max. de chaque minute d'utilisation.

Performance data based on tests using 15W40 oil with a viscosity of 55 cSt (215 SUS) at 54° C (130° F). Performance data is typical. Actual data may vary slightly from one production motor to another.

Les donnees sur les performances sont basees sur des tests utilisant de l'huile 15W40 d'une viscosite de 55 cSt (215 SUS) a 54°C (130°F). Ces donnees correspondent a des situations typiques. Les donnees reelles peuvent varier legerement d'un moteur de production a l'autre.

021 700.indd, js

Intermittierende Werte maximal 10% von jeder Betriebsminute.  
Capacidad de funcionamiento intermitente valida para 10% por cada minuto.

Leistungsdaten sind gemessen mit SAE 15W40 bei einer Viskositäet von 43,1 Cst bei 54°C. Geringfügige Abweichungen von den Katalogerten sind möglich.  
Datos tecnicos obtenidos con aceite 15W40 de 55 cSt (215 SUS) de viscosidad a 54°C (130°F). Los datos proporcionados son valores tipicos. Los valores exactos reales podrian tener una pequena variacion entre distintos motores.



142 Parallel

14.2 cu in / rev

PRESSURE (PSID)

	500	1000	1500	2000	2500	3000	3250
<b>2</b>	925 32	1836 31	2668 26	3467 16			
<b>4</b>	969 65	1920 63	2860 57	3784 46	4619		
<b>6</b>	971 97	1963 94	2886 90	3785 79	4619		
<b>8</b>	954 130	1962 128	2927 125	3858 108	4736		
<b>10</b>	918 163	1933 162	2921 160	3837 145	4724		
<b>12</b>	884 195	1882 193	2886 191	3829 179	4685		
<b>14</b>	857 228	1841 226	2831 224	3796 212	4672		
<b>16</b>	826 260	1799 259	2816 255	3747 246	4630 219	5261 164	
<b>18</b>	790 293	1754 290	2755 286	3703 280	4557 246	5207 197	5523 164
<b>20</b>	757 325	1709 323	2710 322	3661 313	4528 273	5166 226	5472 198
<b>22</b>	726 356	1655 356	2648 353	3603 344	4485 301	5099 245	5259 211
<b>25</b>	452 406	1547 405	2513 403	3441 390	4227 342	4861 278	5068 239
<b>30</b>	374 488	1436 486	2344 484	3225 468	3921 410	4577 334	4921 294

FLOW (GPM)

233 cc / rev

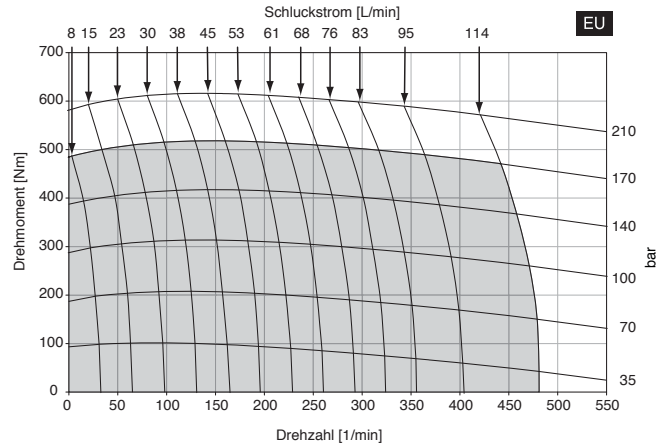

TORQUE (LB IN) 5068  
SPEED (RPM) 239

Cont.  Int.

Intermittent operation rating applies to 10% of every minute.  
Fonctionnement interm. 10% max. de chaque minute d'utilisation.

Performance data based on tests using 15W40 oil with a viscosity of 55 cSt (215 SUS) at 54° C (130° F). Performance data is typical. Actual data may vary slightly from one production motor to another.

Les données sur les performances sont basées sur des tests utilisant de l'huile 15W40 d'une viscosité de 55 cSt (215 SUS) à 54°C (130°F). Ces données correspondent à des situations typiques. Les données réelles peuvent varier légèrement d'un moteur de production à l'autre.

021 700.indd, js

Intermittierende Werte maximal 10% von jeder Betriebsminute.

Capacidad de funcionamiento intermitente valida para 10% por cada minuto.

Leistungsdaten sind gemessen mit SAE 15W40 bei einer Viskosität von 43,1 Cst bei 54°C. Geringfügige Abweichungen von den Katalogerten sind möglich.

Datos técnicos obtenidos con aceite 15W40 de 55 cSt (215 SUS) de viscosidad a 54°C (130°F). Los datos proporcionados son valores típicos. Los valores exactos reales podrían tener una pequeña variación entre distintos motores.

176 Series

8.8 cu in / rev

PRESSURE (PSID)

	500	1000	1500	2000	2500	3000	3500
<b>2</b>	604 52	1204 52	1788 50	2395 49	2913 43	3521 38	
<b>4</b>	588 105	1217 105	1834 105	2445 104	3022 98	3529 90	4142 73
<b>6</b>	548 158	1179 157	1803 157	2423 155	3039 153	3609 143	4142 131
<b>8</b>	497 210	1137 209	1748 210	2364 208	2973 206	3584 201	4162 188
<b>10</b>	436 263	1070 262	1704 261	2291 260	2906 259	3496 256	4098 244
<b>12</b>	371 315	976 315	1601 315	2204 313	2829 311	3441 305	4034 295
<b>14</b>	332 367	899 367	1525 366	2140 363	2717 361	3324 358	3922 353
<b>16</b>	186 420	762 419	1405 418	2017 416	2591 413	3214 410	3814 400
<b>18</b>		665 472	1284 471	1891 468	2468 465	3088 462	3721 450
<b>20</b>		553 524	1134 524	1762 522	2388 519	2975 514	3549 503
<b>22</b>		459 576	1017 576	1636 574	2272 571	2836 565	3417 554
<b>25</b>		81 655	721 655	1375 652	1968 648	2534 637	3113 624
<b>30</b>			284 786	958 782	1562 778	2097 765	2691 749

FLOW (GPM)

144 cc / rev

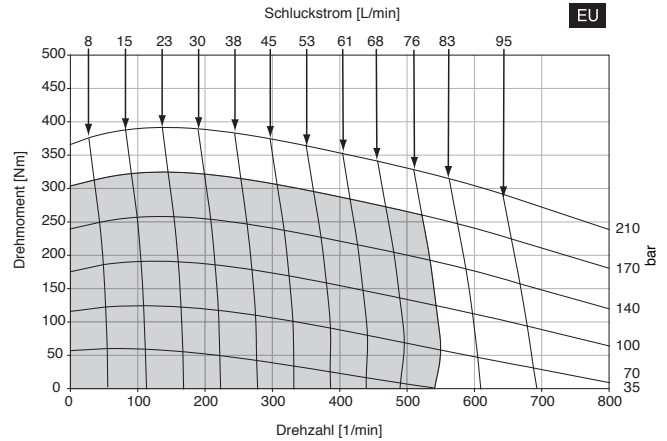

TORQUE (LB IN) 3549  
SPEED (RPM) 503

Cont.  Int.

Intermittent operation rating applies to 10% of every minute.  
Fonctionnement interm. 10% max. de chaque minute d'utilisation.

Performance data based on tests using 15W40 oil with a viscosity of 55 cSt (215 SUS) at 54° C (130° F). Performance data is typical. Actual data may vary slightly from one production motor to another.

Les donnees sur les performances sont basees sur des tests utilisant de l'huile 15W40 d'une viscosite de 55 cSt (215 SUS) a 54°C (130°F). Ces donnees correspondent a des situations typiques. Les donnees reelles peuvent varier legerement d'un moteur de production a l'autre.

021 700.indd, js

Intermittierende Werte maximal 10% von jeder Betriebsminute.  
Capacidad de funcionamiento intermitente valida para 10% por cada minuto.

Leistungsdaten sind gemessen mit SAE 15W40 bei einer Viskositäet von 43,1 Centipoise bei 54°C. Geringfügige Abweichungen von den Katalogerten sind möglich.  
Datos tecnicos obtenidos con aceite 15W40 de 55 cSt (215 SUS) de viscosidad a 54°C (130°F). Los datos proporcionados son valores tipicos. Los valores exactos reales podrian tener una pequena variacion entre distintos motores.

176 Parallel  
17.6 cu in / rev

PRESSURE (PSID)

	500	1000	1500	2000	2250	2500	2750
<b>2</b>	1179 26	2325 26	3403 22				
<b>4</b>	1214 52	2412 51	3601 44	4801 34			
<b>6</b>	1221 79	2479 75	3651 72	4818 64	5338 55		
<b>8</b>	1206 105	2468 104	3693 101	4908 88	5483 83	6050 70	
<b>10</b>	1172 131	2443 130	3685 129	4885 117	5464 108	6036 97	6532 93
<b>12</b>	1130 157	2381 156	3651 155	4874 144	5420 137	5980 125	6394 112
<b>14</b>	1097 184	2345 182	3613 180	4824 171	5408 164	5966 149	6363 130
<b>16</b>	1052 210	2294 209	3567 206	4762 198	5345 189	5924 175	6317 149
<b>18</b>	1003 236	2238 233	3487 229	4689 226	5275 216	5812 208	6255 184
<b>20</b>	955 262	2199 260	3437 258	4639 253	5231 240	5791 231	6209 205
<b>22</b>	922 286	2123 286	3366 283	4566 277	5200 264	5749 254	6147 225
<b>25</b>	832 328	2006 326	3240 324	4431 314	4954 302	5413 289	5816 256
<b>30</b>	689 393	1868 392	3050 389	4224 377	4651 362	5112 347	5546 307

FLOW (GPM)

288 cc / rev

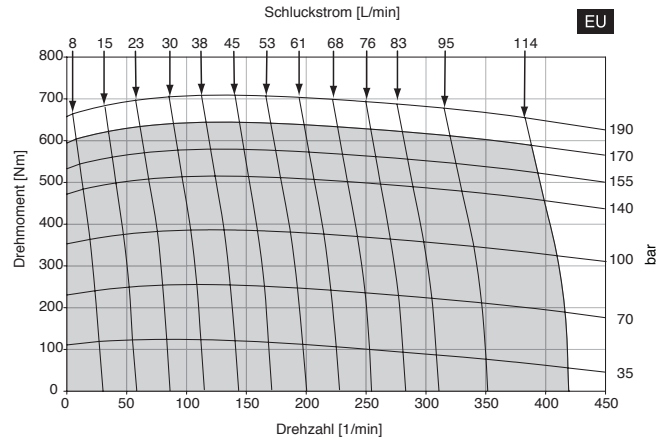

TORQUE (LB IN) 5816  
SPEED (RPM) 256

Cont.  Int.

Intermittent operation rating applies to 10% of every minute.  
Fonctionnement interm. 10% max. de chaque minute d'utilisation.

Performance data based on tests using 15W40 oil with a viscosity of 55 cSt (215 SUS) at 54° C (130° F) Performance data is typical. Actual data may vary slightly from one production motor to another.

Les donnees sur les performances sont basees sur des tests utilisant de l'huile 15W40 d'une viscosite de 55 cSt (215 SUS) a 54°C (130°F). Ces donnees correspondent a des situations typiques. Les donnees reelles peuvent varier legerement d'un moteur de production a l'autre.

021 700.indd, js

Intermittierende Werte maximal 10% von jeder Betriebsminute.  
Capacidad de funcionamiento intermitente valida para 10% por cada minuto.

Leistungsdaten sind gemessen mit SAE 15W40 bei einer Viskosität von 43,1 Cst bei 54°C. Geringfügige Abweichungen von den Katalogerten sind möglich.

Datos tecnicos obtenidos con aceite 15W40 de 55 cSt (215 SUS) de viscosidad a 54°C (130°F). Los datos proporcionados son valores tipicos. Los valores exactos reales podrian tener una pequena variacion entre distintos motores.

212 Series

10.6 cu in / rev

PRESSURE (PSID)

	500	1000	1500	1750	2000	2250	2500	2750	3000	3250
<b>2</b>	731 44	1458 43	2162 42	2509 42	2901 40	3175 39	3532 36			
<b>4</b>	712 87	1468 87	2210 87	2562 87	2946 86	3274 84	3641 81	3955 80	4269 75	4623 71
<b>6</b>	665 131	1426 130	2175 130	2553 129	2920 128	3290 127	3658 127	4009 123	4351 119	4702 115
<b>8</b>	603 174	1371 174	2110 174	2473 173	2854 173	3229 171	3587 170	3961 170	4323 166	4674 161
<b>10</b>	527 218	1287 217	2053 217	2406 216	2767 215	3136 215	3508 214	3872 213	4223 212	
<b>12</b>	450 262	1182 261	1935 261	2315 260	2665 259	3040 258	3414 257	3775 256	4150 251	
<b>14</b>	390 305	1089 304	1844 303	2210 302	2588 301	2940 300	3291 299	3667 298	3948 293	
<b>16</b>	225 349	929 348	1703 347	2076 346	2443 346	2789 345	3149 343	3526 338	3846 335	
<b>18</b>		806 391	1559 391	1921 389	2300 389	2672 388	2995 384	3340 380	3644 377	
<b>20</b>		669 435	1377 435	1769 434	2128 433	2498 432	2741 427	2992 423	3239 418	
<b>22</b>		567 478	1244 478	1612 477	1994 476	2337 475	2657 470	2876 465	3113 460	
<b>25</b>		153 544	900 544	1244 543	1676 541	2037 540	2404 534	2830 528	3037 523	
<b>30</b>			398 653	732 651	1183 650	1534 648	1898 641	2366 641	2531 628	

FLOW (GPM)

174 cc / rev

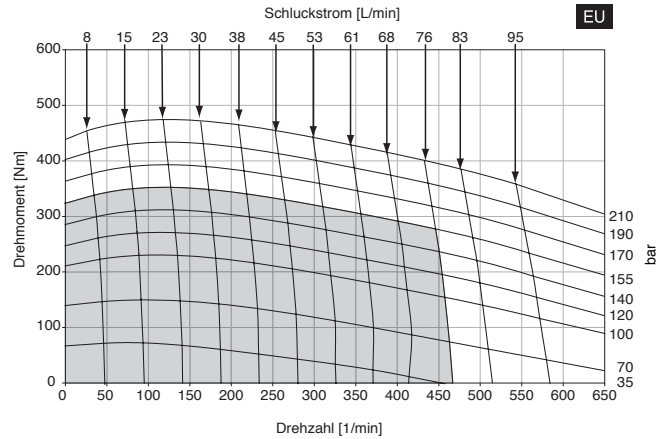

TORQUE (LB IN) 3113  
SPEED (RPM) 460

Cont.  Int.

Intermittent operation rating applies to 10% of every minute.  
Fonctionnement interm. 10% max. de chaque minute d'utilisation.

Performance data based on tests using 15W40 oil with a viscosity of 55 cSt (215 SUS) at 54° C (130° F). Performance data is typical. Actual data may vary slightly from one production motor to another.

Les donnees sur les performances sont basees sur des tests utilisant de l'huile 15W40 d'une viscosite de 55 cSt (215 SUS) a 54°C (130°F). Ces donnees correspondent a des situations typiques. Les donnees reelles peuvent varier legerement d'un moteur de production a l'autre.

021 700.indd, js

Intermittierende Werte maximal 10% von jeder Betriebsminute.  
Capacidad de funcionamiento intermitente valida para 10% por cada minuto.

Leistungsdaten sind gemessen mit SAE 15W40 bei einer Viskositäet von 43,1 Cst bei 54°C. Geringfügige Abweichungen von den Katalogerten sind möglich.  
Datos tecnicos obtenidos con aceite 15W40 de 55 cSt (215 SUS) de viscosidad a 54°C (130°F). Los datos proporcionados son valores tipicos. Los valores exactos reales podrian tener una pequena variacion entre distintos motores.

212 Parallel

21.2 cu in / rev

347 cc / rev

PRESSURE (PSID)

	500	1000	1250	1500	1750	2000	2250	2500
<b>2</b>	1413 22	2789 21	3434 19	4057 18	4676 15	5276 11		
<b>4</b>	1455 44	2874 42	3580 39	4299 36	5036 34	5719 29		
<b>6</b>	1471 65	2970 63	3686 61	4380 60	5047 56	5777 52	6388 46	
<b>8</b>	1455 87	2964 86	3698 85	4429 84	5163 80	5877 73	6498 69	7170 47
<b>10</b>	1413 109	2938 108	3678 108	4429 107	5135 103	5869 98	6520 90	7187 65
<b>12</b>	1366 131	2871 129	3627 129	4390 128	5112 127	5845 120	6492 115	7069 105
<b>14</b>	1326 153	2827 151	3542 150	4256 149	5052 148	5785 143	6476 137	6984 122
<b>16</b>	1269 174	2767 173	3522 172	4241 171	5005 169	5718 165	6400 158	6900 139
<b>18</b>	1215 196	2699 194	3445 193	4207 191	4948 190	5643 188	6326 180	6833 157
<b>20</b>	1158 218	2656 216	3393 215	4153 213	4898 209	5587 210	6210 200	6790 174
<b>22</b>	1114 240	2572 238	3297 237	4068 236	4806 234	5493 230	6226 220	6740 192
<b>25</b>	1004 272	2439 271	3165 270	3897 269	4659 266	5347 261	5982 252	6647 218
<b>30</b>	831 327	2299 325	2973 324	3690 323	4393 319	5093 313	5709 302	6267 262

FLOW (GPM)

Schluckstrom [L/min]

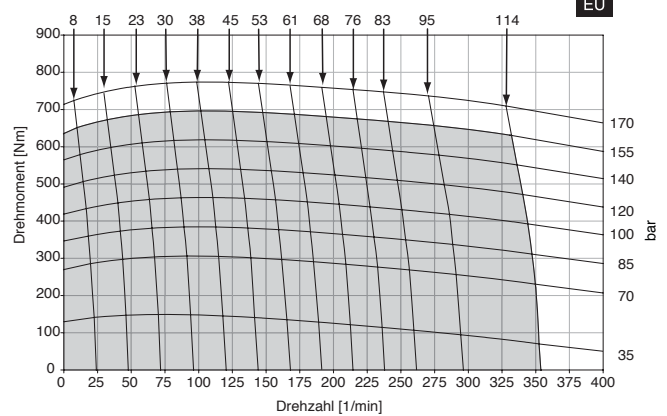

TORQUE (LB IN) 6647  
SPEED (RPM) 218

Cont.  Int.

Intermittent operation rating applies to 10% of every minute.  
Fonctionnement interm. 10% max. de chaque minute d'utilisation.

Performance data based on tests using 15W40 oil with a viscosity of 55 cSt (215 SUS) at 54° C (130° F) Performance data is typical. Actual data may vary slightly from one production motor to another.

Les donnees sur les performances sont basees sur des tests utilisant de l'huile 15W40 d'une viscosite de 55 cSt (215 SUS) a 54°C (130°F). Ces donnees correspondent a des situations typiques. Les donnees reelles peuvent varier legerement d'un moteur de production a l'autre.

021 700.indd, js

Intermittierende Werte maximal 10% von jeder Betriebsminute.  
Capacidad de funcionamiento intermitente valida para 10% por cada minuto.

Leistungsdaten sind gemessen mit SAE 15W40 bei einer Viskosität von 43,1 Cst bei 54°C. Geringfügige Abweichungen von den Katalogerten sind möglich.

Datos tecnicos obtenidos con aceite 15W40 de 55 cSt (215 SUS) de viscosidad a 54°C (130°F). Los datos proporcionados son valores tipicos. Los valores exactos reales podrian tener una pequena variacion entre distintos motores.

258 Series

12.9 cu in / rev

PRESSURE (PSID)

	500	1000	1500	1750	2000	2250	2500	2750	3000
<b>2</b>	905 36	1811 36	2673 35	3155 35	3613 33	3950 33	4414 31	4822 30	5226 26
<b>4</b>	882 72	1799 72	2692 71	3147 71	3585 70	4014 69	4440 66	4850 65	5287 62
<b>6</b>	834 107	1762 107	2645 106	3119 106	3560 104	4000 104	4440 103	4856 101	5318 98
<b>8</b>	757 143	1675 143	2593 142	3036 141	3507 140	3940 139	4399 138	4839 137	5292 135
<b>10</b>	652 179	1556 178	2504 177	2957 176	3400 175	3857 174	4306 173	4771 172	5201 171
<b>12</b>	565 215	1472 213	2390 212	2867 210	3289 208	3737 208	4188 207	4635 207	5072 205
<b>14</b>	423 251	1357 249	2279 249	2731 248	3199 245	3668 243	4096 243	4517 241	4957 239
<b>16</b>	278 287	1187 286	2125 286	2587 285	3043 284	3525 283	3973 283		
<b>18</b>		1006 321	1962 321	2440 319	2911 319	3349 318			
<b>20</b>		827 357	1728 357	2264 356	2620 355	3003 354			
<b>22</b>		758 393	1614 393	2037 392	2546 390	2975 390			
<b>25</b>		466 446	1260 446	1681 446	2135 445	2624 443			
<b>30</b>			773 537	1099 536	1585 535	2079 534			

FLOW (GPM)

TORQUE (LB IN) 1099  
SPEED (RPM) 536

211 cc / rev

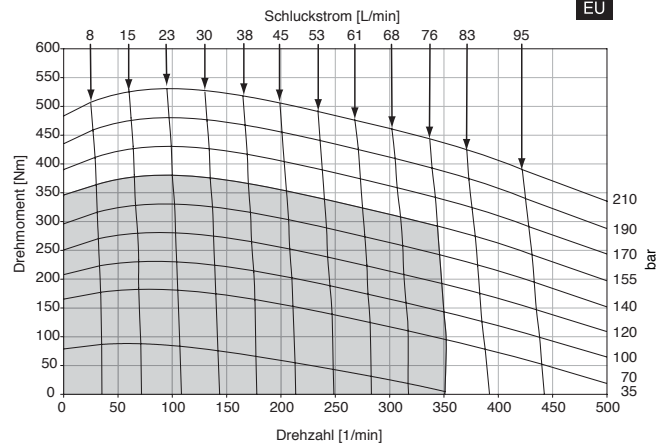

Cont.  Int.

Intermittent operation rating applies to 10% of every minute.  
Fonctionnement interm. 10% max. de chaque minute d'utilisation.

Performance data based on tests using 15W40 oil with a viscosity of 55 cSt (215 SUS) at 54° C (130° F). Performance data is typical. Actual data may vary slightly from one production motor to another.

Les donnees sur les performances sont basees sur des tests utilisant de l'huile 15W40 d'une viscosite de 55 cSt (215 SUS) a 54°C (130°F). Ces donnees correspondent a des situations typiques. Les donnees reelles peuvent varier legerement d'un moteur de production a l'autre.

021 700.indd, js

Intermittierende Werte maximal 10% von jeder Betriebsminute.

Capacidad de funcionamiento intermitente valida para 10% por cada minuto.

Leistungsdaten sind gemessen mit SAE 15W40 bei einer Viskositäet von 43,1 Cst bei 54°C. Geringfügige Abweichungen von den Katalogerten sind möglich.

Datos tecnicos obtenidos con aceite 15W40 de 55 cSt (215 SUS) de viscosidad a 54°C (130°F). Los datos proporcionados son valores tipicos. Los valores exactos reales podrian tener una pequena variacion entre distintos motores.

258 Parallel

25.8 cu in / rev

PRESSURE (PSID)

	500	1000	1250	1500	1750	2000	2250
<b>2</b>	1679 18	3334 15	4055 14	4724 12			
<b>4</b>	1731 36	3474 34	4224 32	5038 30	5979 27	6636 25	
<b>6</b>	1790 54	3531 53	4419 51	5235 48	6072 45	6898 42	7557 38
<b>8</b>	1782 71	3564 71	4435 71	5291 68	6115 66	6981 60	7715 56
<b>10</b>	1727 89	3552 89	4424 88	5340 87	6209 84	7063 81	7853 76
<b>12</b>	1684 107	3511 107	4424 106	5303 104	6187 103	6981 100	7715 97
<b>14</b>	1636 125	3457 124	4373 124	5279 123	6108 123	6915 120	7650 118
<b>16</b>	1556 143	3388 143	4312 143	5223 142	6050 140	6866 138	7594 135
<b>18</b>	1515 161	3301 161	4240 160	5149 160	6022 159	6841 155	7557 151
<b>20</b>	1445 179	3273 179	4193 178	5118 178	5979 178	6800 172	7502 168
<b>22</b>	1378 197	3203 197	4060 196	5020 196	5878 195	6652 189	7391 185
<b>25</b>	1234 224	3084 224	3998 223	4866 222	5763 222	6553 215	7354 210
<b>30</b>	1018 268	3043 268	3798 267	4570 266	5468 266	6225 258	6975 252

FLOW (GPM)

423 cc / rev

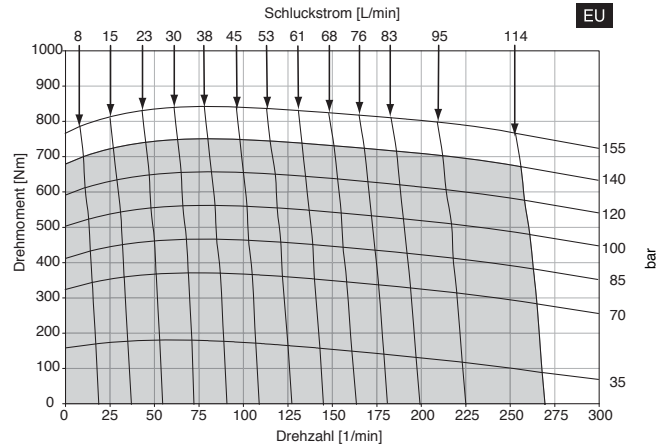

TORQUE (LB IN) 7354  
SPEED (RPM) 210

Cont.  Int.

Intermittent operation rating applies to 10% of every minute.  
Fonctionnement interm. 10% max. de chaque minute d'utilisation.

Performance data based on tests using 15W40 oil with a viscosity of 55 cSt (215 SUS) at 54° C (130° F) Performance data is typical. Actual data may vary slightly from one production motor to another.

Les donnees sur les performances sont basees sur des tests utilisant de l'huile 15W40 d'une viscosite de 55 cSt (215 SUS) a 54°C (130°F). Ces donnees correspondent a des situations typiques. Les donnees reelles peuvent varier legerement d'un moteur de production a l'autre.

021 700.indd, js

Intermittierende Werte maximal 10% von jeder Betriebsminute.  
Capacidad de funcionamiento intermitente valida para 10% por cada minuto.

Leistungsdaten sind gemessen mit SAE 15W40 bei einer Viskosität von 43,1 Cst bei 54°C. Geringfügige Abweichungen von den Katalogerten sind möglich.

Datos tecnicos obtenidos con aceite 15W40 de 55 cSt (215 SUS) de viscosidad a 54°C (130°F). Los datos proporcionados son valores tipicos. Los valores exactos reales podrian tener una pequena variacion entre distintos motores.





700 Series Roller Bearing Allowable Radial Load Curve  
 Chart A

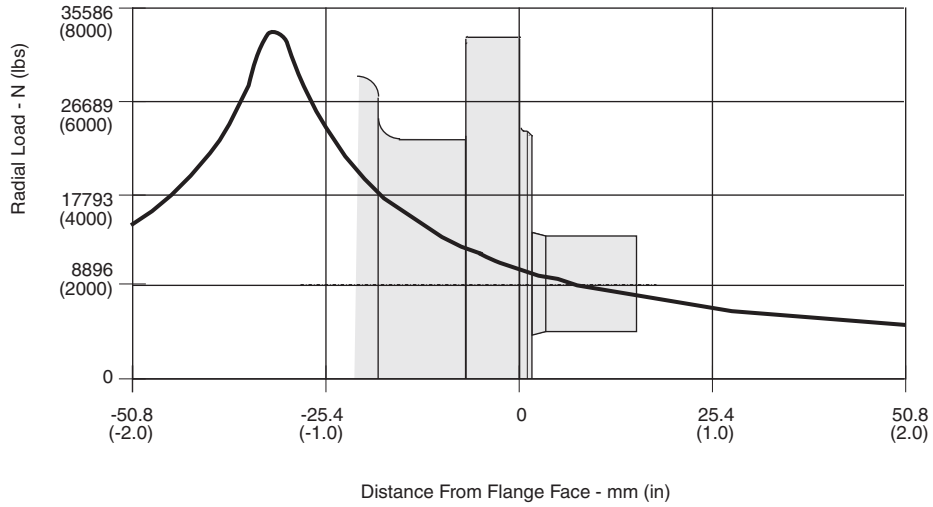

The allowable side load curve is based on  $L_{10}$  bearing life of  $2.5 \times 10^6$  revolutions.  
 Die zulässige radiale Wellenbelastung bezieht sich auf die Lager-Lebensdauer  $2.5 \times 10^6$  Umdrehungen.  
 L'effort radial admissible sur l'arbre depend a une duree de vie  $2.5 \times 10^6$  de rotation.  
 La curva de carga lateral admisible se basa en vida util de cojinete de  $2.5 \times 10^6$  revoluciones.

Bearing Life Factor Curve  
 Chart B

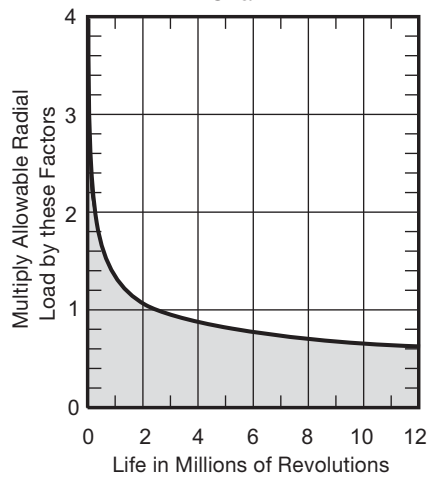

Note:  
 Side load should be considered a vector sum of all imposed loads.

**Code: AM**  
**SAE A, Manifold**

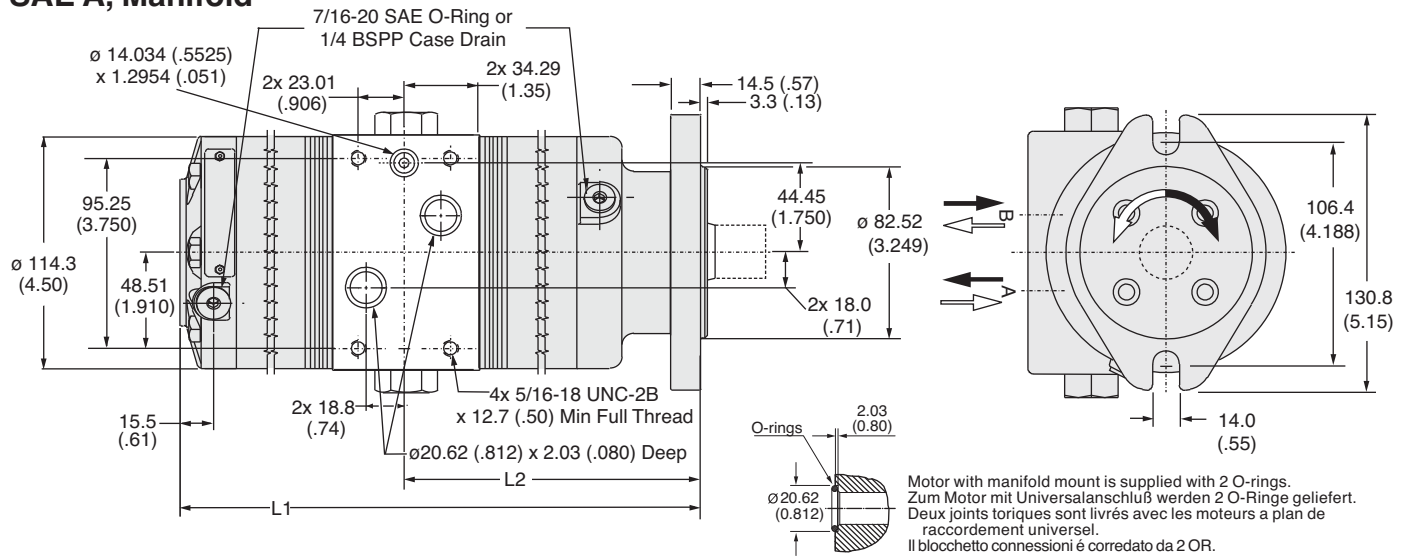

Code AM	072	108	142	176	212	258
Weight/Gewicht	kg 15.9	16.1	16.2	16.4	16.6	16.8
Poids/Peso	(lb) (35.0)	(35.4)	(35.7)	(36.1)	(36.5)	(37.0)
Length	"L1" mm 214.6	224.3	233.7	243.3	253.2	266.0
	"L1" (in) (8.45)	(8.83)	(9.20)	(9.58)	(9.97)	(10.47)
	"L2" mm 123.2	128.0	132.9	137.7	142.5	148.8
	"L2" (in) (4.85)	(5.04)	(5.23)	(5.42)	(5.61)	(5.86)

**Code: AS**  
**SAE A, 7/8"-14 SAE**

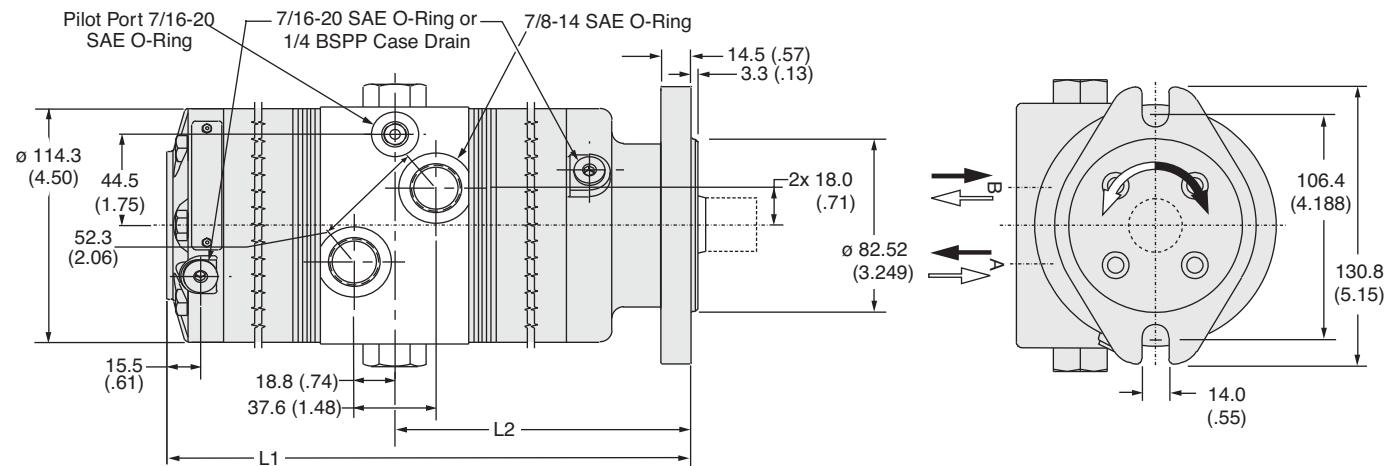

Code AS	072	108	142	176	212	258
Weight/Gewicht	kg 15.9	16.1	16.2	16.4	16.6	16.8
Poids/Peso	(lb) (35.0)	(35.4)	(35.7)	(36.1)	(36.5)	(37.0)
Length	"L1" mm 214.6	224.3	233.7	243.3	253.2	266.0
	"L1" (in) (8.45)	(8.83)	(9.20)	(9.58)	(9.97)	(10.47)
	"L2" mm 123.2	128.0	132.9	137.7	142.5	148.8
	"L2" (in) (4.85)	(5.04)	(5.23)	(5.42)	(5.61)	(5.86)

English equivalents for metric specifications are shown in ( ).

021 700.indd, js

**Code: BM**  
**SAE B, Manifold**

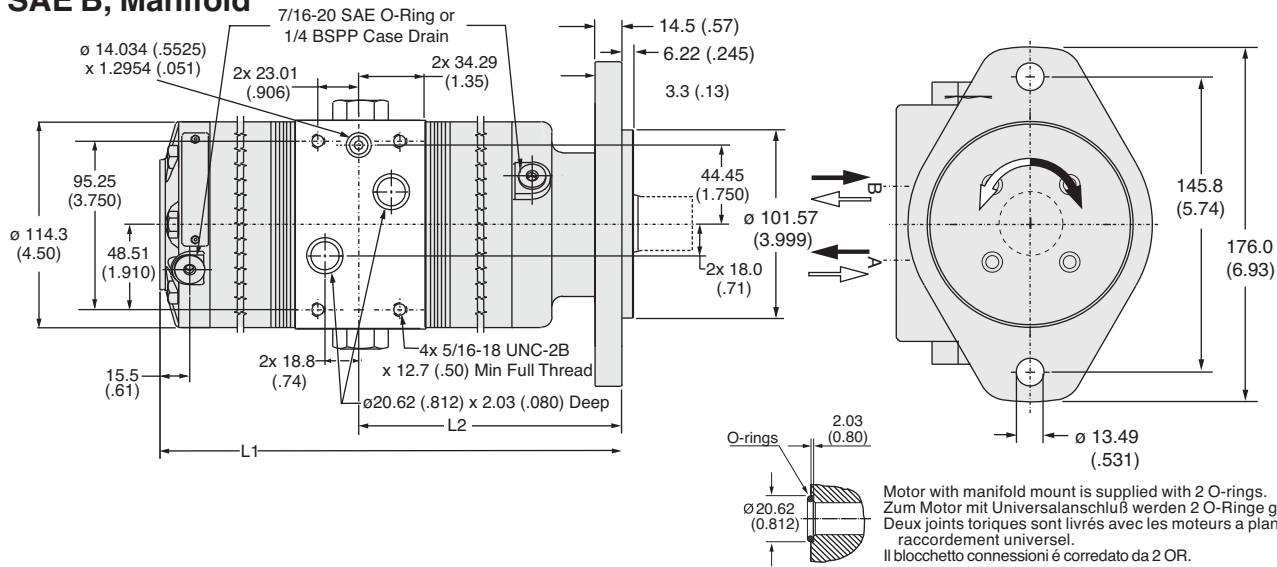

Code BM	072	108	142	176	212	258
Weight/Gewicht kg	15.9	16.1	16.2	16.4	16.6	16.8
Poids/Peso (lb)	(35.0)	(35.4)	(35.7)	(36.1)	(36.5)	(37.0)
Length "L1" mm	214.6	224.3	233.7	243.3	253.2	266.0
	"L1" (in)	(8.45)	(8.83)	(9.20)	(9.58)	(10.47)
"L2" mm	123.2	128.0	132.9	137.7	142.5	148.8
	"L2" (in)	(4.85)	(5.04)	(5.23)	(5.42)	(5.86)

**Code: BS**  
**SAE B, 7/8"-14 SAE**

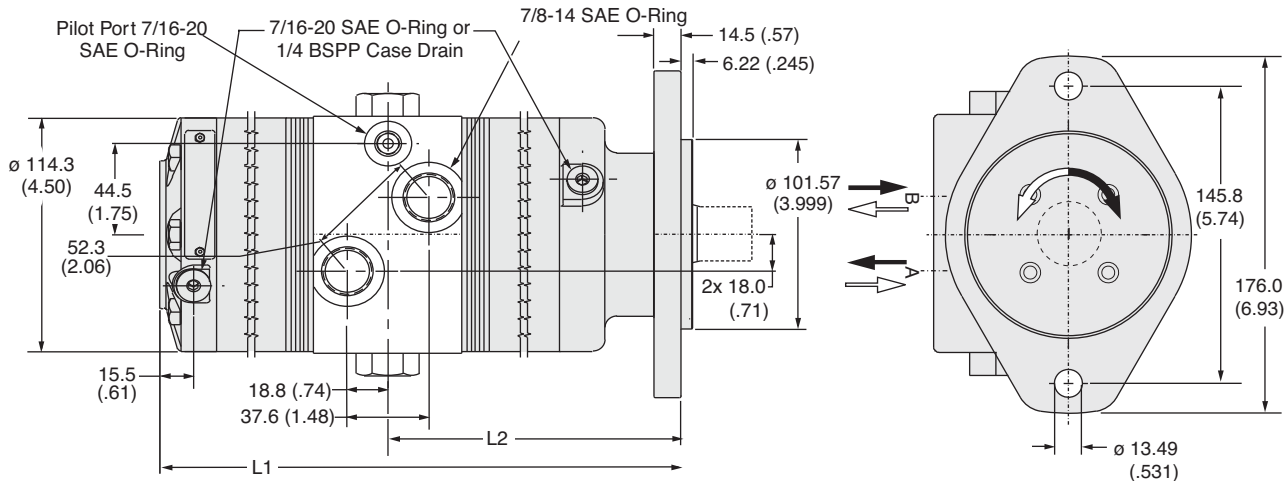

Code BS	072	108	142	176	212	258
Weight/Gewicht kg	15.9	16.1	16.2	16.4	16.6	16.8
Poids/Peso (lb)	(35.0)	(35.4)	(35.7)	(36.1)	(36.5)	(37.0)
Length "L1" mm	214.6	224.3	233.7	243.3	253.2	266.0
	"L1" (in)	(8.45)	(8.83)	(9.20)	(9.58)	(10.47)
"L2" mm	123.2	128.0	132.9	137.7	142.5	148.8
	"L2" (in)	(4.85)	(5.04)	(5.23)	(5.42)	(5.86)

English equivalents for metric specifications are shown in ( ).

021 700.indd, js

**Code: PCL**  
**Remotely Piloted, Closed, Parallel**

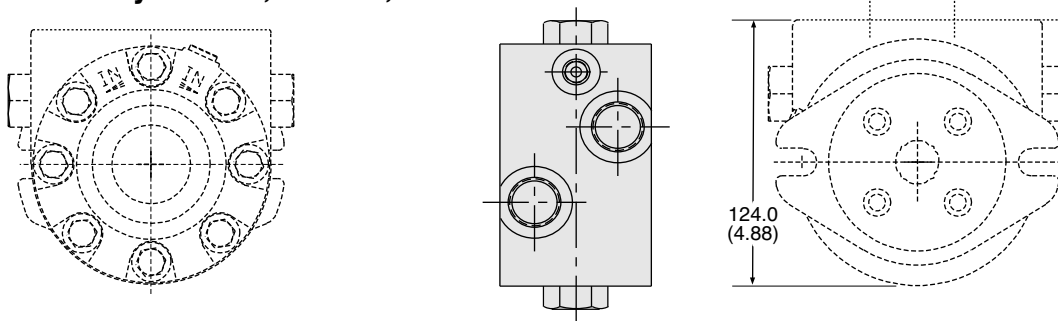

**Code: POL**  
**Remotely Piloted, Open, Parallel**

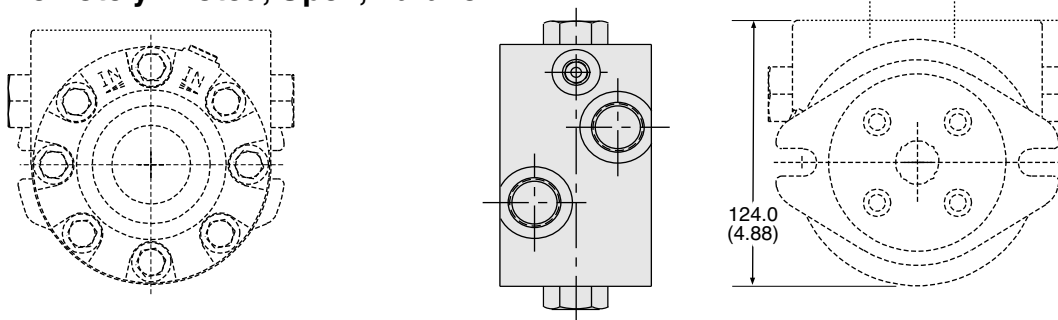

**Code: EOL**  
**Solenoid Actuated with Manual Override, Open, Parallel**

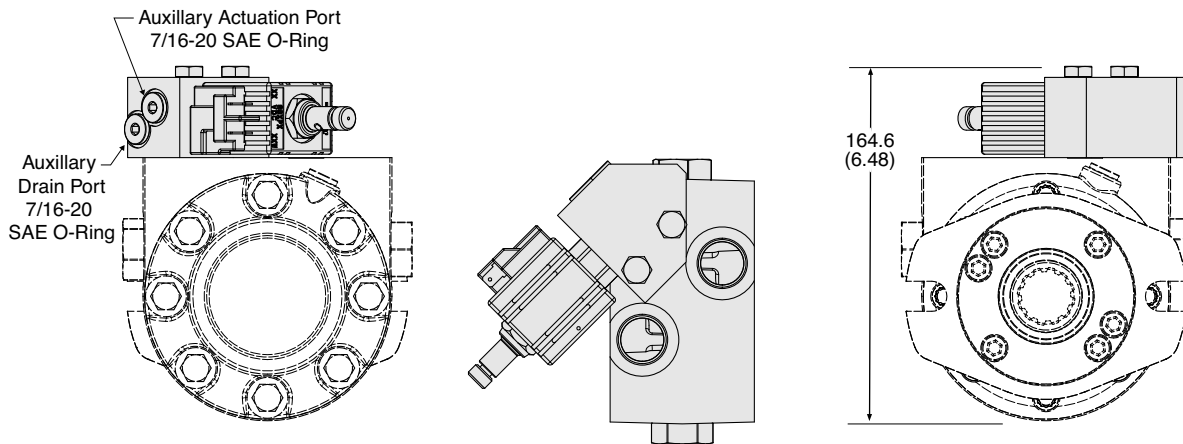

**High Speed Series Mode**

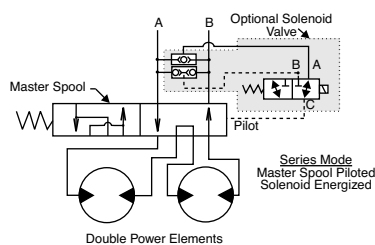

**High Torque Parallel Mode**

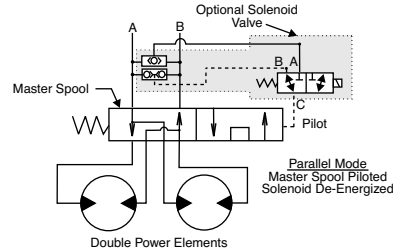

Add .5 kg (1.1 lb) for this option.  
 English equivalents for metric specifications are shown in ( ).

021 700.indd, js

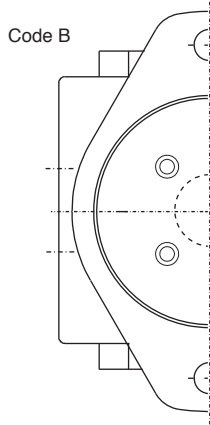
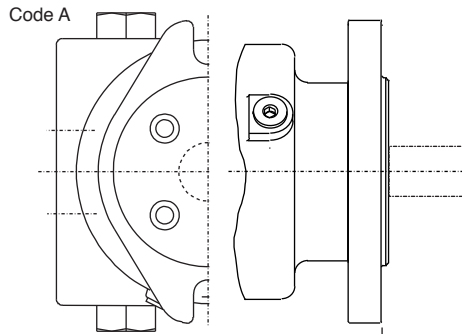

**Code: 0**

**1" Keyed**

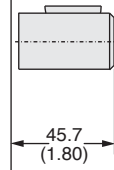

**Code: 3**

**1-1/4" Keyed**

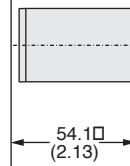

**Code: 5**

**1-1/4"-14 Tooth Spline**

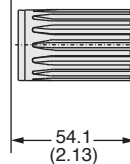

English equivalents for metric specifications are shown in ( ).

021 700.indd, js

Code: 0

1" Keyed

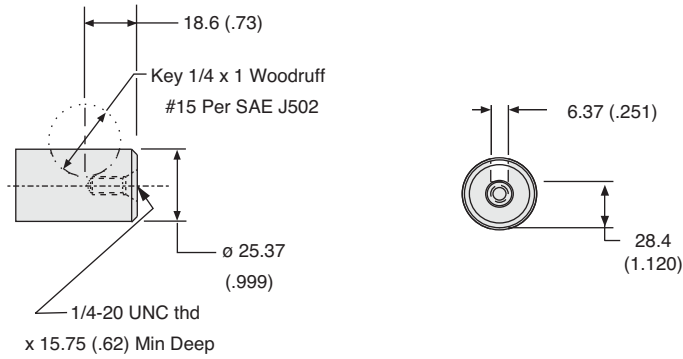

Code: 3

1-1/4" Keyed

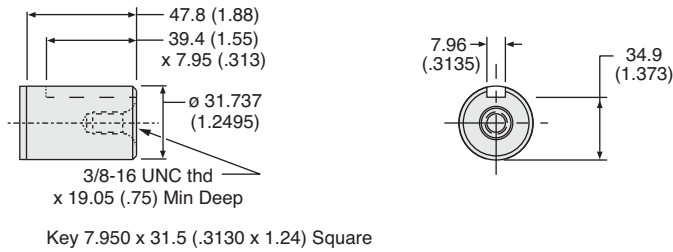

Code: 5

1-1/4"-14 Tooth Spline

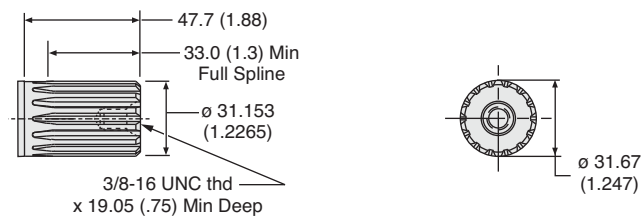

English equivalents for metric specifications are shown in ( ).

021 700.indd, js